



Tough Computers for Tough Conditions

APC Technology is a specialist designer and manufactures state of the art computer/control technology packages for industrial and military clients who have critical applications where failure is not an option.

FT Panel PCs and displays are dual sealed to prevent the ingress of dust and liquids. All **FT Units** are rated to IP66, making them the ideal solution for rural and industrial environments which experience constant exposure to moisture and dirt.

FT Panel PCs and displays are specifically designed for monitoring and control applications within abattoirs & meatworks, livestock management, food production and pharmaceutical manufacturing environments.

Main Features & Benefits

- Rugged all metal construction
- Touchscreen option
- Fully Sealed stainless steel units
- Sunlight readable displays
- Wide dimming range rating available
- Wide temperature range
- Customised and versatile
- Tried and proven components



Real life application of FT Unit



"We continually liaise with the customer at all stages to ensure that performance requirements are met and that any solution provided by APC remains relevant"



Stainless Steel Construction

Stainless steel is specified for use in food plants, and offers excellent mechanical strength and corrosion resistance.

Complimenting this, the **FT units** have a streamline design which eliminates gaps and collection points preventing the build up of waste products.

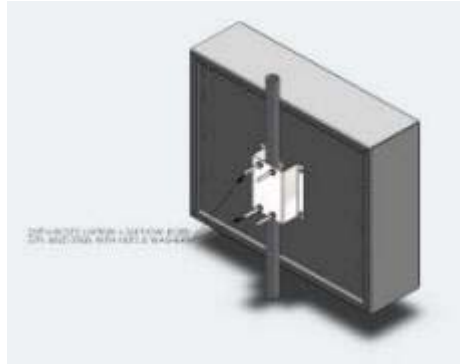

Mounting Options

APC Technology have developed a range of mounting options to suit your requirements.



Optional Touchscreen

Projected capacitive technology enables the pointing device to be sensed through an optical protective screen in front of the display.

This highly dependable, low maintenance system, also offers unrivalled protection against a wide range of physical threats for the most demanding of touchscreen applications.

New General Manager, APC Technology

About Us

As of July 2009 Mr Scott Begbie has been appointed General Manager of **APC Technology**. This follows the decision of Mr Roy Armstrong to step down from the day to day role as Managing Director. Roy continues as a Director on the board of **APC** where his experience continues to be a valuable asset.

Scott has been with **APC Technology** since 2000 with the last 6 years being in the role of Engineering Manager.

Request Sales information or Quote

Contact Us

For more information about our product range or to discuss a solution specific to your requirements, please Contact Us at sales@apctechnology.com.au or via phone +61 8 8363 0400

With a worldwide sales and trading partner network we are strategically placed to provide you with dedicated solutions and support for all your system requirements.

APC Technology Associations

Tough Computers for Tough Conditions



CONFIDENTIALITY AND COPYRIGHT NOTICE © 2008
This communication is copyright to Automation and Process Control Services Pty Ltd (APC Technology). If you believe you have received this communication in error, or do not wish to receive similar communication in the future please unsubscribe using the form at the bottom of this email.