



TOUGH COMPUTERS FOR TOUGH CONDITIONS

APC TECHNOLOGY E-TIMES

SEPTEMBER/OCTOBER 2008

Military Systems

APC Technology is an accredited supplier of computer systems to the Australian Department of Defence and currently has systems in service with all Defence forces - Army, Navy and Air Force.

As such, we are uniquely placed to provide totally integrated solutions designed for all extremes of defence force operations.



COMMAND & CONTROL



Situational Awareness is the ability to identify, process, and comprehend the critical elements of information with regards to the mission. Our command and control equipment delivers optimal awareness and performance for the operator within a versatile ergonomically designed format.



LAND WARFARE



The BMS (Battlefield Management System) is a Command and Control system especially developed for Land Warfare Applications. Our Battlefield Management System utilises ruggedised hardware specifically developed for harsh environmental

requirements.



PROTOTYPE DESIGNS



Our rugged, integrated workstations offer the optimum in command and control solutions - versatile, capable and ergonomically designed to deliver. We can provide a reliable solution for the most demanding of applications.

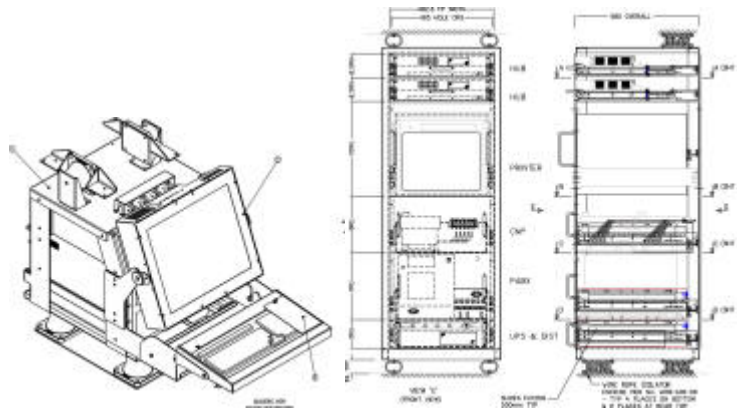

EMBEDDED COTS SOLUTIONS



Aitech is a leading supplier of rugged computer systems optimised for harsh environments offering:

- VME and CompactPCI for defence and space applications
- COTS, radiation tolerant and MIL-SPEC solutions
- VMEbus and CompactPCI boards, enclosures and sub-systems
- Hardware system integration



RUGGED PORTABLE SOLUTIONS



Innovative fully rugged laptops and tablet PCs that not only survive but excel in extreme environments. Our range of rugged portable solutions feature magnesium alloy chassis, rubber gasket seals to protect the entire unit from water, dust or sand. No fans or openings for a totally sealed environment. Heat pipe channel technology allows the case to act as a large heat sink for

cooler operation. O-Ring gasket seals the system tight.



FIND OUT MORE



For more information about our product range or to discuss a solution specific to your requirements please contact us at sales@apctechnology.com.au or via phone on 08 8363 0400

With a worldwide sales and trading partner network we are strategically placed to provide you with dedicated solutions and support for all your system requirements.



“We continually liaise with the customer at all stages to ensure that performance requirements are met and that any solution provided by APC remains relevant”

APC TECHNOLOGY SOLUTIONS

Real World Solutions



Do you have the perfect product for your application?

Will your product survive its intended environment?

For over 20 years **APC Technology** have provided rugged solutions designed to survive the harshest environments on earth.

We are now able to offer this as a separate service to our clients with the ability to take COTS solutions and ruggedise them to ensure they survive any application in any

environment in any location.

REQUEST SALES INFORMATION OR QUOTE

Contact Us

For more information about our product range or to discuss a solution specific to your requirements, please Contact Us at

sales@apctechnology.com.au or via phone +61 8 8363 0400

With a worldwide sales and trading partner network we are strategically placed to provide you with dedicated solutions and support for all your system requirements.

UPCOMING EVENTS

Tough Computers for Tough Conditions

APC Technology will be displaying our product range at the following upcoming events. View our product range and talk to our friendly sales team about how **APC Technology** can customise our solutions to suit your industrial and military application.

Land Warfare 08



Avalon Airshow



APC TECHNOLOGY ASSOCIATIONS

Tough Computers for Tough Conditions



CONFIDENTIALITY AND COPYRIGHT NOTICE © 2008

This communication is copyright to Automation and Process Control Services Pty Ltd (APC Technology). If you believe you have received this communication in error, or do not wish to receive similar communications in the future please unsubscribe using the form at the bottom of this email.

www.apctechnology.com.au
Copyright© Automation & Process Control Services Pty. Ltd.
ACN 008 044 451